

Technique parameter		
	inner tank	jacket
material	304	304
working pressure MPa	0.15	0.3
design pressure MPa	0.15	0.3
tatal volume	717L	
working volume	600L	

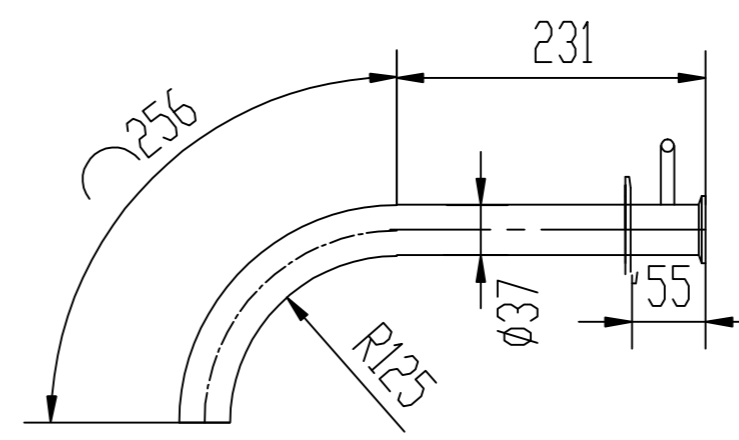

man hole



### Specification

symbol	spec	connecting style	name
a	1.5"	Tri-clamp	outlet
b	1.5"	Tri-clamp	outlet
c	1.5"	Tri-clamp	Relief valve
d	2.5"-1.5"	Tri-clamp	cleaning hole
e	ø430x330	quick-opened	man hole
f	1.5"	Tri-clamp	Thermometer
g	1.5"	Tri-clamp	sample hole
i1-2	1.5"	Tri-clamp	Glycol inlet
j1-2	1.5"	Tri-clamp	Glycol outlet
M	1.5"	Tri-clamp	CO2 Connection
h	4"	Tri-clamp	Hop port

